



Parts Manual



Walk Behind Mowers

19" & 21"

Attachments

Mfg. No.	Description
881633	ESPV19875EXAL, 19" Self Propelled Walk Mower (Export)
881634	ESPV21875EXAL, 21" Self Propelled Walk Mower (Export)

Manual Part No. 1754030

Revision A

Rev. Date: 1/25/2013

Not for
Reproduction

PRODUCT COMPONENTS	PAGES
Handle Assembly	4
Deck & Engine Group	6
Decals Group	10
Drive Group	12
Torque Specification Chart	Inside Back Cover

Not for
Reproduction

Handle Assembly

NOTE: Unless noted otherwise,
use the standard hardware torque
specification chart.

881220

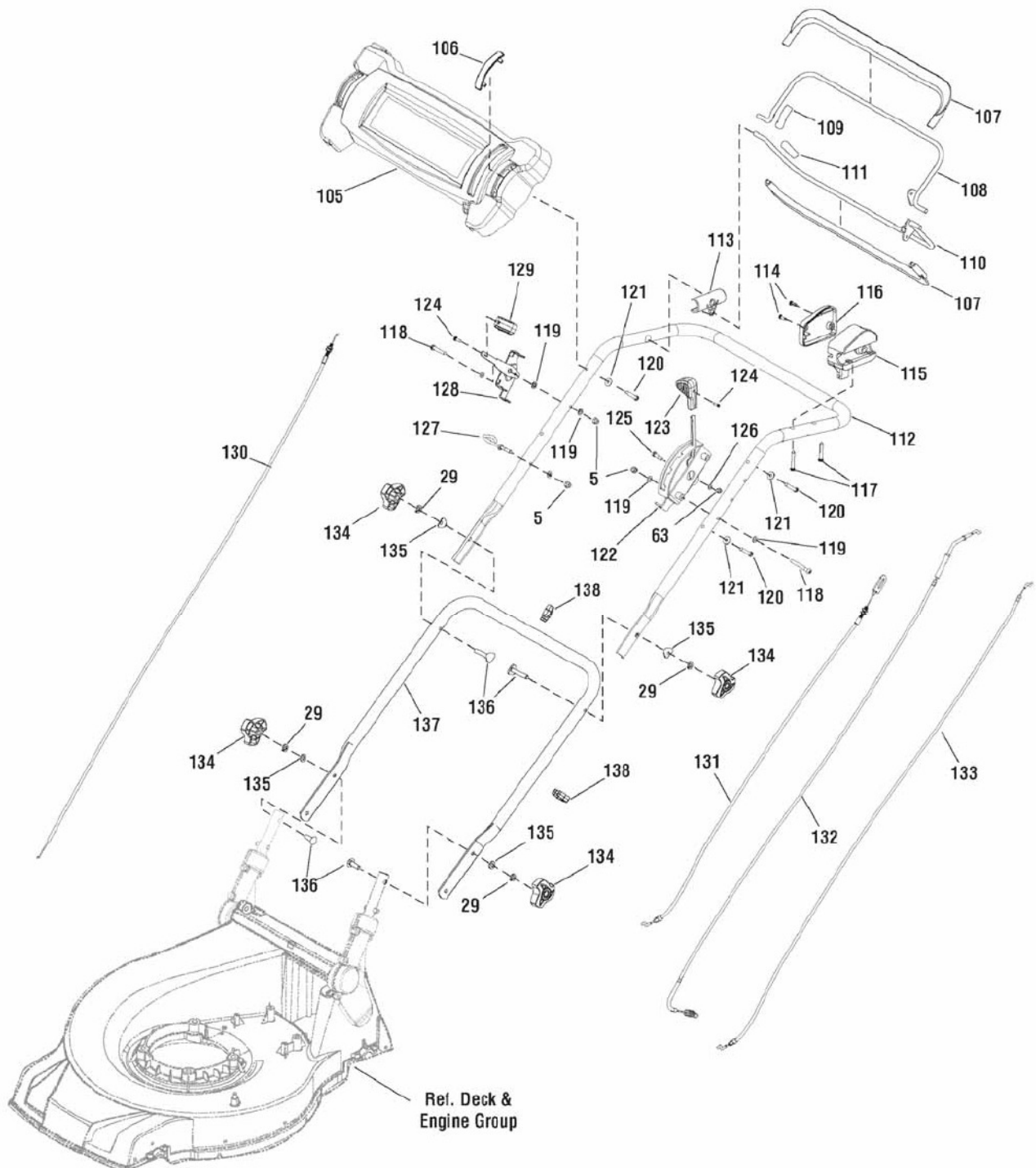

The above parts group applies to the following Mfg. Nos.:

881633 - ESPV19875EX

881634 - ESPV21875EX

Handle Assembly

REF NO	PART NO.	QTY.	DESCRIPTION
5	701183	3	NUT, Hex, Nylon Insert, Torque Type
29	701231	4	WASHER, Spring
63	701218	1	NUT, Hex, Nylon Insert, Torque Type
105	701279	1	PANEL, Handle Cover (Used on 19" Decks)
105	701317	1	PANEL, Handle Cover (Used on 21" Decks)
106	701281	1	INSERT, Throttle Cover
107	701284	2	COVER, Handle (Used on 19" Decks)
107	701321	2	COVER, Handle (Used on 21" Decks)
108	701232	1	LEVER, Brake (Used on 19" Decks)
108	701322	1	LEVER, Brake (Used on 21" Decks)
109	701233	1	COVER, Brake Lever
110	701234	1	LEVER, Clutch (Used on 19" Decks)
110	701323	1	LEVER, Clutch (Used on 21" Decks)
111	701235	1	COVER, Clutch Lever
112	701236	1	HANDLE, Upper (Used on 19" Decks)
112	701324	1	HANDLE, Upper (Used on 21" Decks)
113	701285	1	HINGE
114	701237	2	SCREW, Pan Head, Cross Recessed Tapping
115	701369	1	CABLE BOX, Control Lever
116	701286	1	COVER, Cable Box
117	701465	2	SCREW, Pan Head, Cross Recessed Tapping (Used on 19" Decks)
117	701238	2	SCREW, Pan Head, Cross Recessed Tapping (Used on 21" Decks)
118	701239	3	SCREW, Pan Head, Cross Recessed, H-Form
119	701240	8	WASHER, Flat, C Class
120	701241	4	SCREW, Pan Head, Cross Recessed Tapping
121	701242	4	WASHER, A-Form
122	701370	1	FRAME, Speed Adjustment
123	701371	1	GRIP, Speed Adjustment
124	701243	2	SCREW, Pan Head, Cross Recessed Tapping
125	701372	1	BOLT, Speed Adjustment Cable
126	701373	1	WASHER, Flat, C-Class
127	701244	1	HOOK, Start Rope
128	701325	1	FRAME, Throttle
129	701245	1	GRIP, Throttle
130	702138	1	CABLE, Throttle
131	701374	1	CABLE, Speed Adjustment
132	701288	1	CABLE, Clutch
133	701289	1	CABLE, Brake
134	701248	4	KNOB, Lock
135	701249	4	WASHER, Curved
136	701250	4	BOLT, Connecting
137	701320	1	HANDLE, Lower (Used on 19" Decks)
137	701375	1	HANDLE, Lower (Used on 21" Decks)
138	701290	2	CLIP, Cable

Footnotes

The above parts group applies to the following Mfg. Nos.:

881633 - ESPV19875EX

881634 - ESPV21875EX

Deck & Engine Group

NOTE: Unless noted otherwise,
use the standard hardware torque
specification chart.

881633

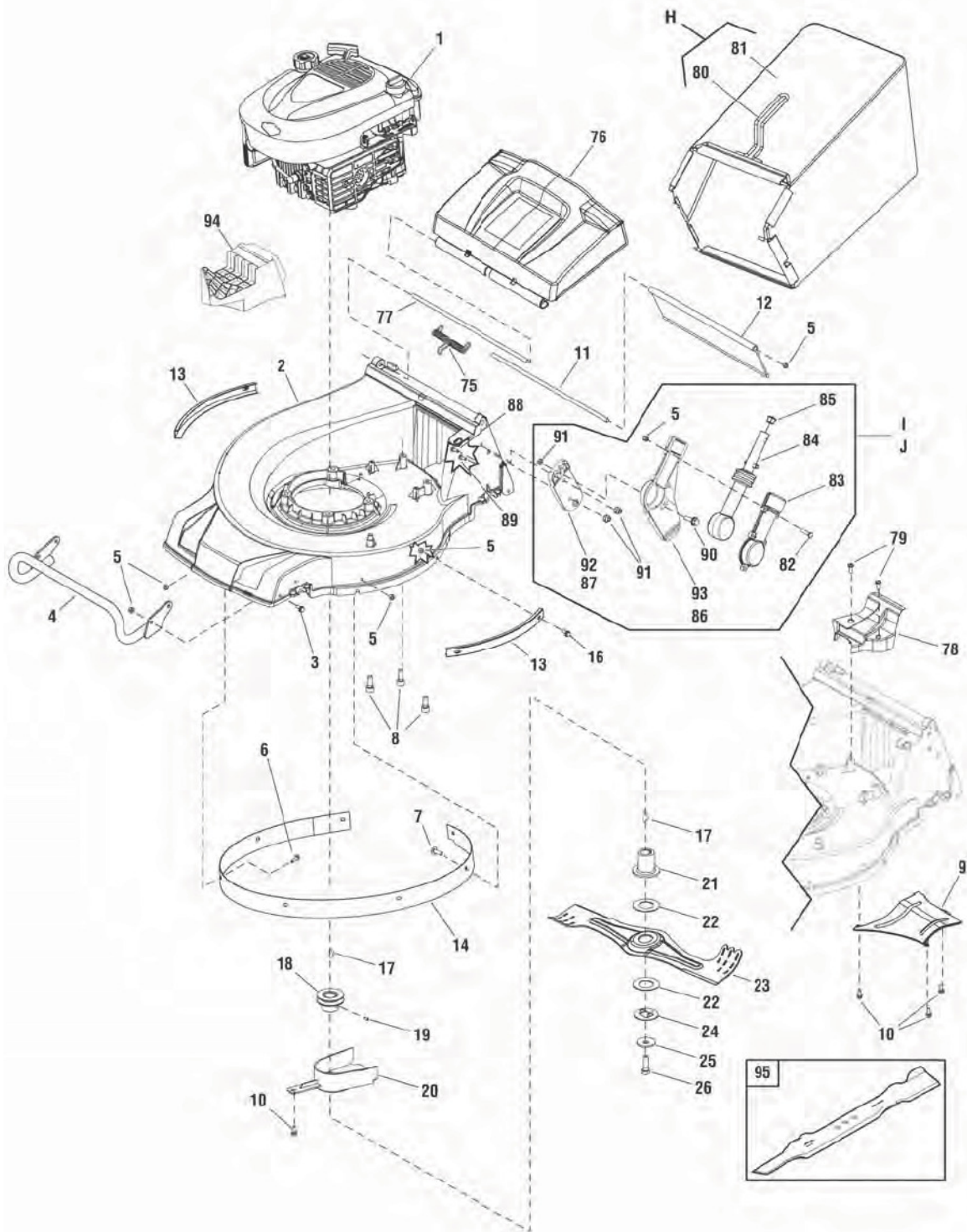

The above parts group applies to the following Mfg. Nos.:

881633 - ESPV19875EX

881634 - ESPV21875EX

Deck & Engine Group

REF NO	PART NO.	QTY.	DESCRIPTION
1	122S02-0110-H1	1	** ENGINE, 875 Series, Briggs & Stratton (Engine Model: 122S02-0110-H1)
2	701180	1	DECK, 19"
2	701291	1	DECK, 21"
3	701181	4	BOLT, Hex Flange
4	701182	1	BUMPER, 19"
4	701328	1	BUMPER, 21"
5	701183	12	NUT, Hex, Nylon Insert, Torque Type
6	701184	3	SCREW, Truss Head, Cross Recessed
7	701185	4	SCREW, Truss Head, Cross Recessed
8	701186	4	SCREW, Inner Hexagon, Round Head, Tapping
9	701252	1	DEFLECTOR, Lower (Used on 19" Decks)
9	701329	1	DEFLECTOR, Lower (Used on 21" Decks)
10	701187	5	SCREW, Hex Flange, Tapping
11	701188	1	SHAFT, Rear Deflector (Used on 19" Decks)
11	701292	1	SHAFT, Rear Deflector (Used on 21" Decks)
12	701189	1	DEFLECTOR, Rear (Used on 19" Decks)
12	701293	1	DEFLECTOR, Rear (Used on 21" Decks)
13	701190	2	SHIELD, Outer (Used on 19" Decks)
13	701294	2	SHIELD, Outer (Used on 21" Decks)
14	701253	1	SHIELD, Inner Ring (Used on 19" Decks)
14	701295	1	SHIELD, Inner Ring (Used on 21" Decks)
16	701297	4	BOLT, Hex Flange
17	701192	2	KEY, Woodruff
18	701331	1	PULLEY, Engine
19	701298	1	SCREW, Inner Hexagon Recessed
20	701299	1	SHIELD, Lower Belt
21	701255	1	ADAPTOR, Blade
22	701256	2	DISC, Friction
23	701195	1	BLADE, 19"
23	701332	1	BLADE, 21"
24	701257	1	CLIP
25	701196	1	SPRING, Dishing
26	701197	1	BOLT, Blade
75	701223	1	SPRING, Torsion (Used on 19" Decks)
75	701310	1	SPRING, Torsion (Used on 21" Decks)
76	701276	1	COVER, Rear (Used on 19" Decks)
76	701311	1	COVER, Rear (Used on 21" Decks)
77	701224	1	SHAFT, Rear Cover (Used on 19" Decks)
77	701312	1	SHAFT, Rear Cover (Used on 21" Decks)
78	701225	1	SHIELD, Upper Pulley (Used on 19" Decks)
78	701313	1	SHIELD, Upper Pulley (Used on 21" Decks)
79	701226	2	SCREW, Inner Hexagon Tapping
H	701227	1	GRASS CATCHER ASSEMBLY (Used on 19" Decks) (Includes Ref. Nos. 73 & 74)
H	701314	1	GRASS CATCHER ASSEMBLY (Used on 21" Decks) (Includes Ref. Nos. 73 & 74)

Footnotes

** Purchase engine parts from engine manufacturer dealer.

The above parts group applies to the following Mfg. Nos.:

881633 - ESPV19875EX

881634 - ESPV21875EX

Deck & Engine Group

NOTE: Unless noted otherwise,
use the standard hardware torque
specification chart.

881633

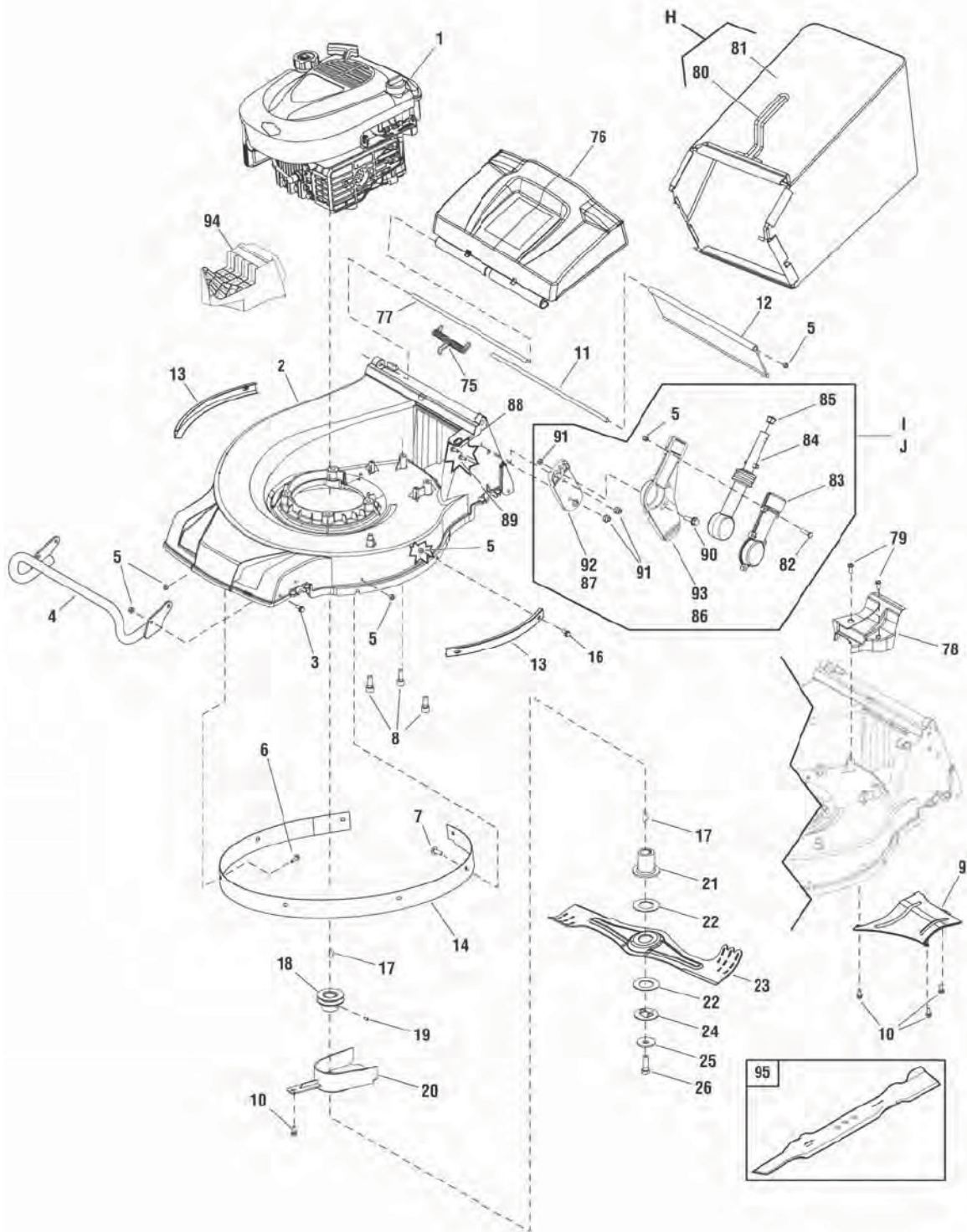

The above parts group applies to the following Mfg. Nos.:

881633 - ESPV19875EX

881634 - ESPV21875EX

Deck & Engine Group

REF NO	PART NO.	QTY.	DESCRIPTION
80	----	1	FRAME, Grass Catcher, 19" Deck (Not a serviceable part, order Ref. H)
80	----	1	FRAME, Grass Catcher, 21" Deck (Not a serviceable part, order Ref. H)
81	----	1	BAG, Grass Catcher, 19" Deck (Not a serviceable part, order Ref. H)
81	----	1	BAG, Grass Catcher, 21" Deck (Not a serviceable part, order Ref. H)
I	701346	1	BRACKET ASSEMBLY, RH (Includes Ref. Nos. 5, 82, 83, 84, 85, 86, 87, 90 & 91)
J	701354	1	BRACKET ASSEMBLY, LH (Includes Ref. Nos. 5, 82, 83, 84, 85, 90, 91, 92 & 93)
82	701347	6	BOLT, Hexangular, Full Thread
83	701348YP	2	COVER, Bracket
84	701349YP	2	AVS ASSEMBLY
85	----	2	AVS PLUG (Not a serviceable part, order Ref. I or J)
86	701351YP	1	BRACKET, Handle, RH
87	701352YP	1	BASE, Bracket, RH
88	701319	2	BOLT, Carriage
89	701229	2	BOLT, Carriage
90	701353	2	BOLT, Hex Flange
91	701228	9	NUT, Nylon Insert, Torque Type
92	701355YP	1	BASE, Bracket, LH
93	701356YP	1	BRACKET, Handle, LH
94	702120	1	PLUG, Mulch, 19"
94	702122	1	PLUG, Mulch, 21"
95	702119	1	BLADE, Mulching, 19" (Optional Accessory)
95	702121	1	BLADE, Mulching, 21" (Optional Accessory)

Footnotes

** Purchase engine parts from engine manufacturer dealer.

The above parts group applies to the following Mfg. Nos.:

881633 - ESPV19875EX

881634 - ESPV21875EX

Decals Group

NOTE: Unless noted otherwise,
use the standard hardware torque
specification chart.

881220dl

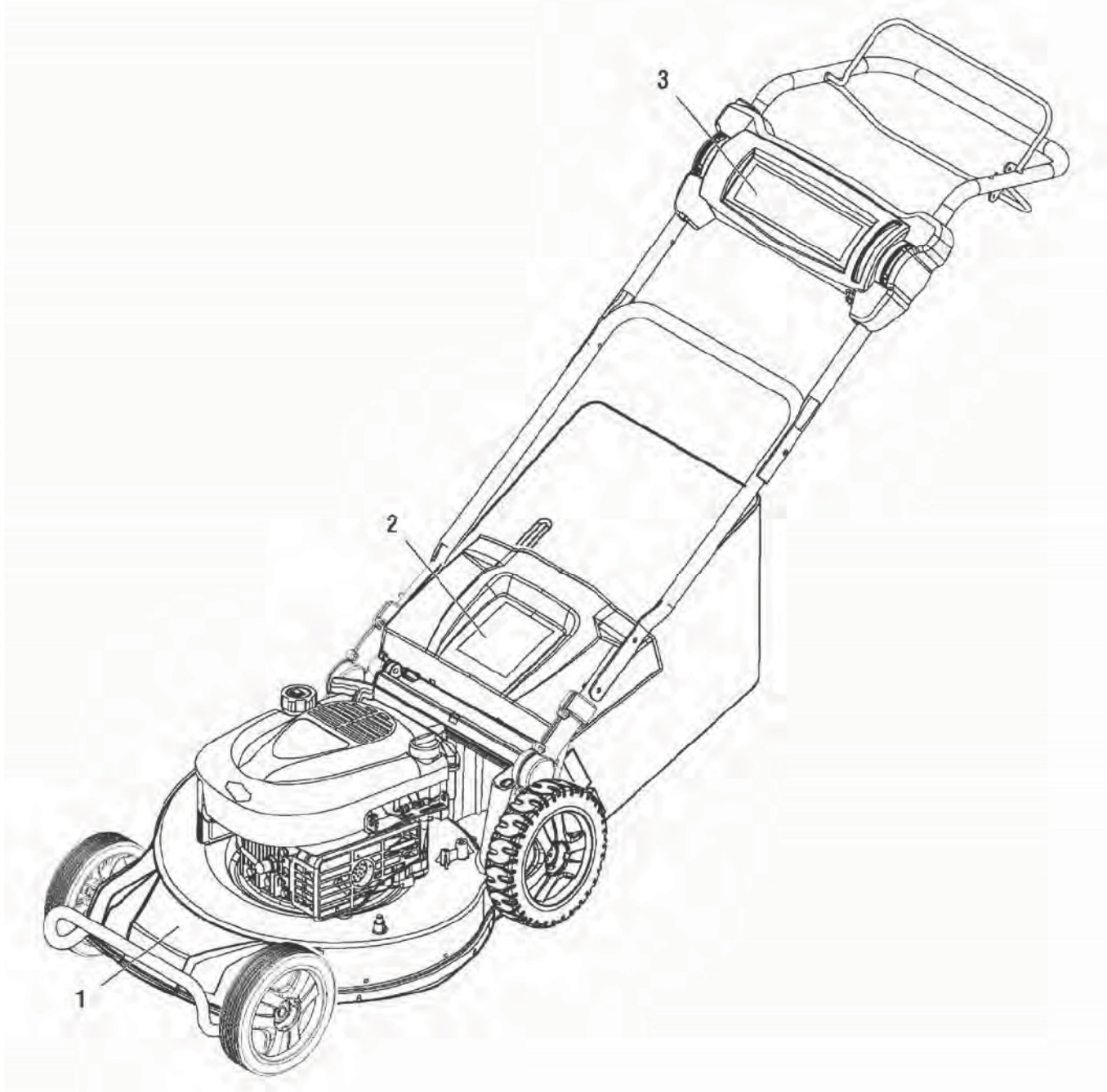

The above parts group applies to the following Mfg. Nos.:

881633 - ESPV19875EX

881634 - ESPV21875EX

Decals Group

REF NO	PART NO.	QTY.	DESCRIPTION
1	881240	1	DECAL, Logo, Deck
2	881442	1	DECAL, Safety
3	1722551	1	DECAL, Logo, Cover

Not for
Reproduction

Footnotes

The above parts group applies to the following Mfg. Nos.:

881633 - ESPV19875EX

881634 - ESPV21875EX

Drive Group

NOTE: Unless noted otherwise, use the standard hardware torque specification chart.

881220

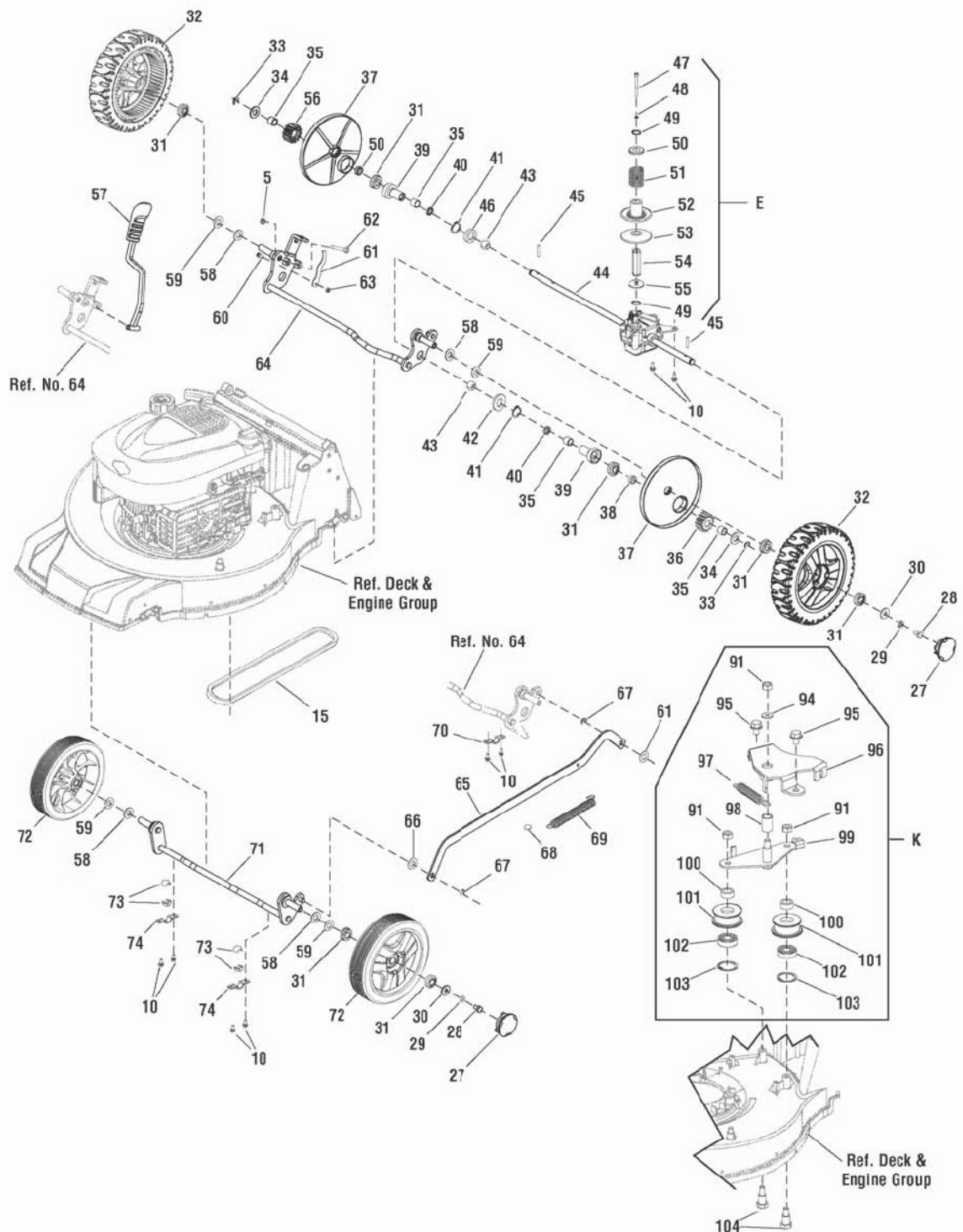

The above parts group applies to the following Mfg. Nos.:

881633 - ESPV19875EX

881634 - ESPV21875EX

Drive Group

REF NO	PART NO.	QTY.	DESCRIPTION
5	701183	1	NUT, Hex, Nylon Insert, Torque Type
10	701187	14	SCREW, Hex Flange, Tapping
15	701326	1	V-BELT, V10 x 795 (Used on 19" Decks)
15	701296	1	V-BELT, V10 x 845 (Used on 21" Decks)
27	701258	4	COVER, Wheel
28	701259	4	BOLT, Hexangular, Full Thread
29	701231	8	WASHER, Spring
30	701230	4	WASHER, Flat, C Class
31	701199	10	BEARING
32	701260	2	WHEEL, Rear, Self-Propelled, 8" (Used on 19" Decks)
32	701333	2	WHEEL, Rear, Self-Propelled, 9" (Used on 21" Decks)
33	701261	2	CHECK RING
34	701201	2	WASHER, Anti-Friction
35	701202	4	OIL BEARING B
36	701203	1	PINION, Left
37	701205	2	SHIELD, Dust, Rear (Used on 19" Decks)
37	701302	2	SHIELD, Dust, Rear (Used on 21" Decks)
38	701204	2	SPACER, Main Axle
39	701262	2	BEARING SHEATH
40	701206	2	RING, Dustproof
41	701263	2	RING, Elastic, For A-form Axle
42	701264	1	WASHER, Left Bearing Bracket
43	701207	2	BALL BEARING, Nylon
44	701464	1	TRANSMISSION, 486 (Used on 19" Decks)
44	701335	1	TRANSMISSION, 538 (Used on 21" Decks)
45	701210	2	PIN, Sliding
46	701211	1	SPACER, Transmission
E	701336	1	SPEED VARIATOR ASSEMBLY (Includes Ref. Nos. 47, 48, 49, 50, 51, 52, 53, 54 & 55)
47	701337	1	CAPSCREW, Hexagon Socket Head
48	701338	1	WASHER, Spring
49	701339	2	RING, Elastic, For A-Form Axle
50	701340	1	RING, Spring Shield
51	----	1	SPRING, Compression (Not a serviceable part, order Ref. E)
52	----	1	Mobile Disc of Pulley (Not a serviceable part, order Ref. E)
53	----	1	DISC, Lower Pulley (Not a serviceable part, order Ref. E)
54	----	1	ADAPTOR (Not a serviceable part, order Ref. E)
55	701345	1	WASHER, Inner Hexagon
56	701212	1	PINION, Right
57	701213	1	LEVER, Height Adjust
58	701214	4	WASHER, Wheel Axle
59	701269	4	WASHER, Spring
60	701215	1	BOLT, Hexangular, Full Thread (Used on 19" Decks)
60	701304	1	BOLT, Hexangular, Full Thread (Used on 21" Decks)
61	701216	1	SPRING, Armature

Footnotes

The above parts group applies to the following Mfg. Nos.:

881633 - ESPV19875EX

881634 - ESPV21875EX

Drive Group

NOTE: Unless noted otherwise, use the standard hardware torque specification chart.

881220

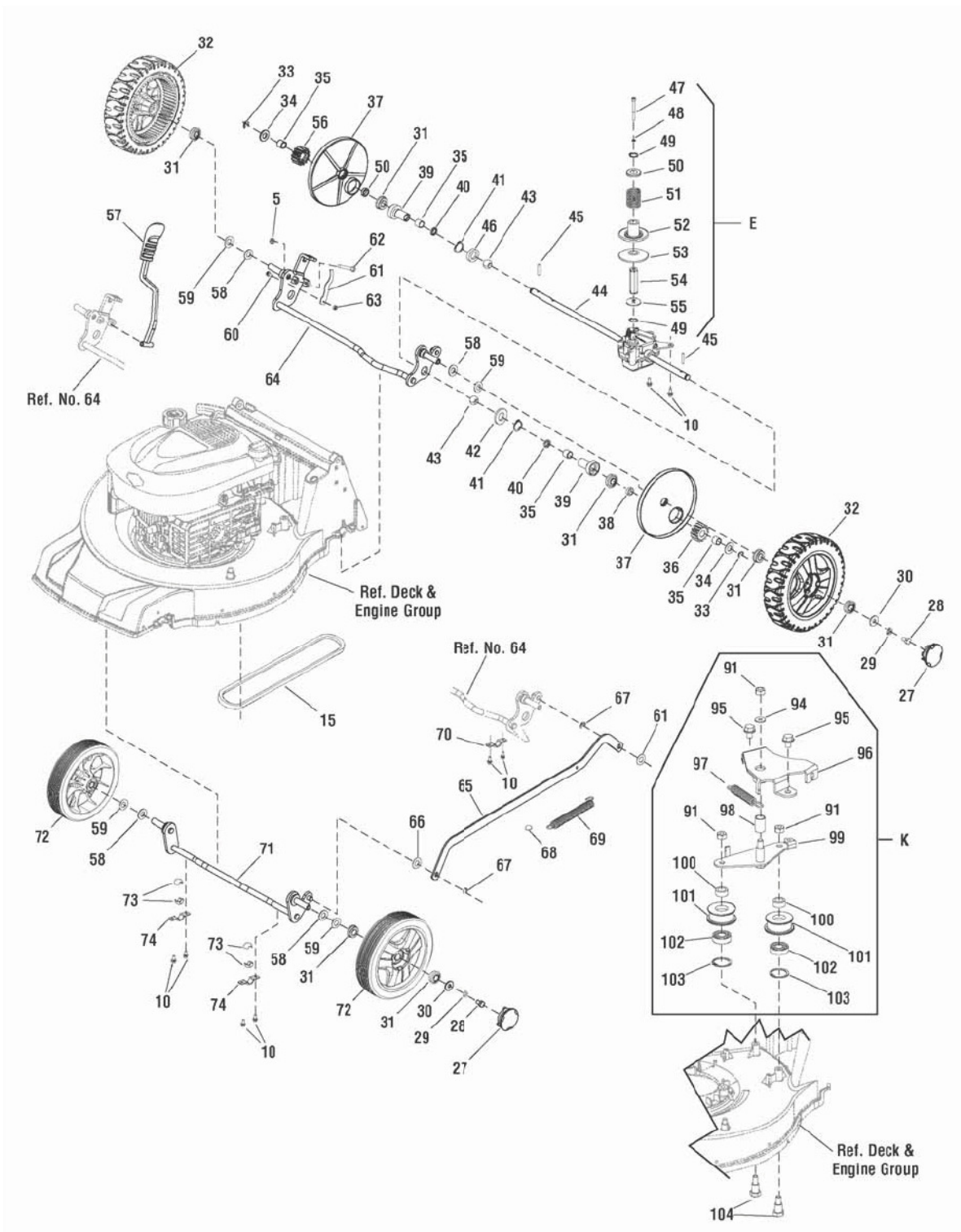

The above parts group applies to the following Mfg. Nos.:

881633 - ESPV19875EX

881634 - ESPV21875EX

Drive Group

REF NO	PART NO.	QTY.	DESCRIPTION
62	701217	1	BOLT, Hexangular
63	701218	2	NUT, Hex, Nylon Insert, Torque Type
64	701219	1	AXLE, Rear (Used on 19" Decks)
64	701305	1	AXLE, Rear (Used on 21" Decks)
65	701268	1	CONNECTING ROD (Used on 19" Decks)
65	701306	1	CONNECTING ROD (Used on 21" Decks)
66	701220	2	MAT, Nylon
67	701270	2	CHECK RING
68	701271	1	CHECK CAP
69	701272	1	SPRING, Connecting Rod (Used on 19" Decks)
69	701307	1	SPRING, Connecting Rod (Used on 21" Decks)
70	701273	2	BRACKET, Upper Ball Bearing
71	701221	1	AXLE, Front (Used on 19" Decks)
71	701308	1	AXLE, Front (Used on 21" Decks)
72	701274	2	WHEEL, Front, 8"
73	701222	4	BALL BEARING
74	701275	2	BRACKET, Front Ball Bearing
K	701357	1	TENSIONAL MECHANISM ASSEMBLY (Includes Ref. Nos. 91, 94, 95, 96, 97, 98, 99, 100, 101, 102, 103 & 104)
91	701228	3	NUT, Hex, Nylon Insert, Torque Type
94	701358	1	WASHER
95	701359	2	BOLT, Hex Flange, Tapping
96	----	1	PLATE, Tension (Not a serviceable part, order Ref. K)
97	701361	1	SPRING, Tension
98	701362	2	SPACER, Nylon
99	----	1	PLATE, Double Pulley (Not a serviceable part, order Ref. K)
100	----	2	SPACER, Pulley (Not a serviceable part, order Ref. K)
101	----	2	PULLEY, Tensional (Not a serviceable part, order Ref. K)
102	----	2	BALL BEARING, Deep Groove, 6001 (Not a serviceable part, order Ref. K)
103	----	2	RING, Elastic, For A-Form Hole (Not a serviceable part, order Ref. K)
104	701368	2	BOLT, Pulley

Footnotes

The above parts group applies to the following Mfg. Nos.:

881633 - ESPV19875EX

881634 - ESPV21875EX

Not for
Reproduction

Not for
Reproduction

Not for
Reproduction

Hardware Identification & Torque Specifications

Torque Specification Chart								
FOR STANDARD METRIC MACHINE HARDWARE (Tolerance ± 20%)								
Property Class	5.6		8.8		10.9		12.9	
	Class 5.6		Class 8.8		Class 10.9		Class 12.9	
Size Of Hardware	in/lbs		in/lbs		in/lbs		in/lbs	
	ft/lbs	Nm.	ft/lbs	Nm.	ft/lbs	Nm.	ft/lbs	Nm.
M3	5.88	.56	13.44	1.28	19.2	1.80	22.92	2.15
M4	13.44	1.28	30.72	2.90	43.44	4.10	52.56	4.95
M5	26.4	2.50	60.96	5.75	5.97	8.10	7.15	9.7
M6	44.64	4.3	7.3	9.9	10.3	14	12.1	16.5
M7	5.2	7.1	12.1	16.5	16.9	23	19.9	27
M8	7.7	10.5	17.7	24	25	34	29	40
M10	15	21	35	48	50	67	59	81
M12	26	36	61	83	86.2	117	103	140
M14	42	58	101	132	136	185	162	220
M16	64	88	147	200	210	285	250	340
M18	89	121	202	275	287	390	346	470
M20	126	171	290	390	405	550	486	660
M22	169	230	390	530	559	745	656	890
M24	217	295	497	375	708	960	840	1140
M27	320	435	733	995	1032	1400	1239	1680
M30	435	590	995	1350	1401	1900	1681	2280
M33	590	800	1349	1830	1902	2580	2278	3090
M36	759	1030	1740	2360	2441	3310	2935	3980
M39	988	1340	2249	3050	3163	4290	3798	5150

Torque Specification Chart						
FOR STANDARD MACHINE HARDWARE (Tolerance ± 20%)						
Hardware Grade	No Marks		SAE Grade 5		SAE Grade 8	
	SAE Grade 2		SAE Grade 5		SAE Grade 8	
Size Of Hardware	in/lbs		in/lbs		in/lbs	
	ft/lbs	Nm.	ft/lbs	Nm.	ft/lbs	Nm.
8-32	19	2.1	30	3.4	41	4.6
8-36	20	2.3	31	3.5	43	4.9
10-24	27	3.1	43	4.9	60	6.8
10-32	31	3.5	49	5.5	68	7.7
1/4-20	66	7.6	8	10.9	12	16.3
1/4-28	76	8.6	10	13.6	14	19.0
5/16-18	11	15.0	17	23.1	25	34.0
5/16-24	12	16.3	19	25.8	29	34.0
3/8-16	20	27.2	30	40.8	45	61.2
3/8-24	23	31.3	35	47.6	50	68.0
7/16-14	30	40.8	50	68.0	70	95.2
7/16-20	35	47.6	55	74.8	80	108.8
1/2-13	50	68.0	75	102.0	110	149.6
1/2-20	55	74.8	90	122.4	120	163.2
9/16-12	65	88.4	110	149.6	150	204.0
9/16-18	75	102.0	120	163.2	170	231.2
5/8-11	90	122.4	150	204.0	220	299.2
5/8-18	100	136	180	244.8	240	326.4
3/4-10	160	217.6	260	353.6	386	525.0
3/4-16	180	244.8	300	408.0	420	571.2
7/8-9	140	190.4	400	544.0	600	816.0
7/8-14	155	210.8	440	598.4	660	897.6
1-8	220	299.2	580	788.8	900	1,244.0
1-12	240	326.4	640	870.4	1,000	1,360.0

The guides and ruler furnished below are designed to help you select the appropriate hardware.



Nut, M8

Thread Diameter (mm)
Inside Diameter (in) Threads per inch

Nut, 1/2-16

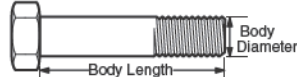

Screw, M8- 1.25 x 25

Thread Diameter (mm) Distance between threads (mm) Body Length (mm)
Body Diameter Threads per inch Body Length (in)

Screw, 1/2- 16 x 2



Standard Hardware Sizing

When a washer or nut is identified as 1/2" (M8), this is the *Nominal size*, meaning the *inside diameter* is 1/2 inch (8mm metric thread diameter); if a second number is present it represents the *threads per inch* (distance between threads).

When bolt or capscrew is identified as 1/2 - 16 x 2" (M8 - 1.25 x 50), this means the *Nominal size*, or body diameter is 1/2 inch (8mm metric thread diameter), the second number, 16, represents the *threads per inch*, (1.25 thread diameter). The final number is the body length of the bolt or screw, 2 inches (50mm).

NOTES

- These torque values are to be used for all hardware excluding: locknuts, self-tapping screws, thread forming screws, sheet metal screws and socket head setscrews.
- Recommended seating torque values for locknuts:
 - for prevailing torque locknuts - use 65% of grade 5 torques.
 - for flange whizlock nuts and screws - use 135% of grade 5 torques.
- Unless otherwise noted on assembly drawings, all torque values must meet this specification.

Common Hardware Types

Hex Head Capscrew



Washer



Carriage Bolt



Hex Nut

Wrench & Fastener Size Guide

1/4" Bolt or Nut Wrench—7/16"	5/16" Bolt or Nut Wrench—1/2"	3/8" Bolt or Nut Wrench—9/16"	7/16" Bolt or Nut Wrench (Bolt)—5/8" Wrench (Nut)—11/16"	1/2" Bolt or Nut Wrench—3/4"
M6 Bolt or Nut Wrench—10mm	M8 Bolt or Nut Wrench—13mm	M10 Bolt or Nut Wrench—17mm	M12 Bolt or Nut Wrench—19mm	M14 Bolt or Nut Wrench—22mm

Not for
Reproduction

**IT IS THE POLICY OF BRIGGS & STRATTON CORP. TO IMPROVE ITS PRODUCTS
WHENEVER IT IS POSSIBLE AND PRACTICAL TO DO SO. WE RESERVE THE RIGHT TO
MAKE CHANGES OR ADD IMPROVEMENTS AT ANY TIME WITHOUT INCURRING ANY
OBLIGATION TO MAKE SUCH CHANGES ON PRODUCTS.**

Briggs & Stratton Yard Power Products Group

3515 N. 124 Street / PO Box 702
Wauwatosa, WI 53222 USA

www.simplicitymfg.com

© Copyright 2013 by Briggs & Stratton Corporation
Milwaukee, WI, USA. All rights reserved

